

# Next Generation BITS Modernization: No Place for Learning on the Job

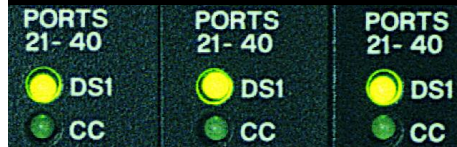

# Next Generation BITS Modernization: No Place for Learning on the Job

## Introduction

The Building Integration Timing Supply (BITS) concept is the basis for providing synchronization throughout today's Central Office. The BITS hardware foundation is a combination of a synchronization reference, such as a Primary Reference Source (PRS) and a BITS Master Shelf, which distributes synchronization signals to the Central Office's (CO's) network elements. Converting from legacy to Next Generation BITS is the subject of this paper.

Even the briefest BITS outage has the potential to disrupt telephone and internet communications to thousands of customers. Recognizing the importance of the BITS, many telecommunications providers are in the process of upgrading to Next Generation BITS equipment such as the TimeHub 5500. These companies face major challenges in considering the pros and cons of the wide range of configuration options for new BITS Master shelves. They then face another obstacle in installing the new systems, particularly the critical cutover phase of the installation when the heartbeat of the entire CO is transferred from the old to the new system. At this critical moment, mistakes of any type are simply not an option.

The critical process of configuring and installing a new BITS Master shelf is no place to gain on-the-job experience. Symmetricom's certified Field Service Engineers (FSEs) provide the know-how that is needed to sort among multiple options for configuring the new BITS Master shelf and recommend the optimal solution from a reliability, performance, and cost standpoint. FSEs also provide the experience, earned over years working with Telco COs or through stringent training and certification, that is needed to manage the installation process. Before they move a single connection, our professionals prepare and present a detailed Method of Procedure (MOP) for your approval. They will then

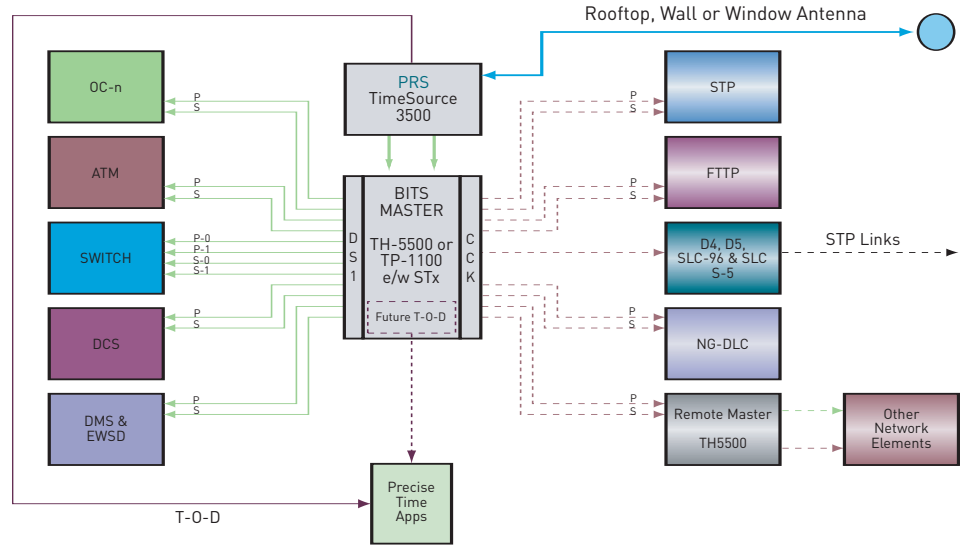

Building Integrated Timing Supply (BITS) Typical Configuration with GPS Reference: TimeSource 3500 and Time of Day Application

perform the BITS upgrade and the crucial cutover phase with the confidence and precision that can only be acquired from doing the job correctly, time after time, first in a lab environment and only then in the critical CO environment.

## Failure is Not an Option

Today's COs contain multiple switches and network elements, each of which is capable of handling thousands of calls simultaneously. Each phone call or Internet connection is typically routed through multiple switches and network elements in different COs. All of these devices must operate on exactly the same digital heartbeat provided by a BITS Master Shelf. If the shelf fails or loses its accuracy, even for an instant, calls are dropped, emails don't go through, customer complaints pile up and Service Level Agreements are violated. The situation has become even more critical recently as explosive growth in telecommunications volume has led to faster and more

powerful data transmission technologies. These technologies in turn require more powerful and more accurate synchronization capabilities.

Many COs are addressing these challenges by implementing powerful new Timing Signal Generators (TSGs) such as the TimeHub 5500 from Symmetricom. The TimeHub 5500 Master shelf provides up to 140 1+1 protected outputs and expansion shelves can be added to increase the capacity to over 1,400 outputs. The TimeHub system also provides full visibility and manageability of all input and output ports and can be modified and controlled through multiple interfaces including Ethernet. The question of how to integrate a powerful TSG into the existing BITS infrastructure is a critical one since the alternative that is selected has a major impact on both the cost and reliability of the upgrade. Symmetricom has developed several different categories of BITS modernization options and will work closely with you to determine which synchronization modernization alternative will provide the best blend of reliability, performance, and cost.

## BITS Modernization Alternatives

One option involves temporarily maintaining your old TSG (typically a Digital Clock Distributor [DCD] system) as a remote system that receives references from the new TimeHub 5500, which becomes the new CO BITS Master Shelf. The CO Master shelf is cabled to a new High-Density Wire Wrap panel, which provides connections to the remote system and the newly installed CO network elements. The primary advantage of this configuration is the in-place wiring between the legacy system and the network elements stays in place. This substantially reduces the amount of labor required for new system installation and allows you the flexibility to move network element synchronization to the new system at a later date, rather than at new system installation. A disadvantage is that the legacy platform may experience performance and maintenance problems, due to product age and component obsolescence. Another potential disadvantage is that many existing BITS shelves were installed prior to 1992, when specifications began calling for diversity in the wiring patterns. Even though the legacy Master may have dual references, the possibility that these references are run adjacent to each other nullifies, to some degree, the inherent advantages of redundancy.

A second option takes nearly the opposite approach by removing the existing legacy TSG, the wire wrap panel and all wiring to the network elements. This equipment is replaced with a new TSG, High-Density Wire Wrap panel and new Shielded Twisted Pair cable to the network elements. This approach provides the advantage of removing the legacy TSG, which eliminates the potential for maintenance problems that may be associated with older equipment. This approach also ensures that the BITS employs both redundancy and diversity to the utmost possible degree to provide the ultimate in survivability. On the other hand, the disadvantage of this approach is the immediate cost of the labor involved in rewiring the synchronization connection to each of the network elements.

A third option provides an alternative that falls in between the first two options. The legacy TSG and wire wrap panel are removed and replaced with next-generation TimeHub 5500 Master shelves and High-Density Wire Wrap panels. The new wire wrap panel is used to extend synchronization signals to the newly installed network elements. The wire wrap panels associated with the legacy TSG system are kept in place and connected to the new TimeHub via extender and "Y" connector

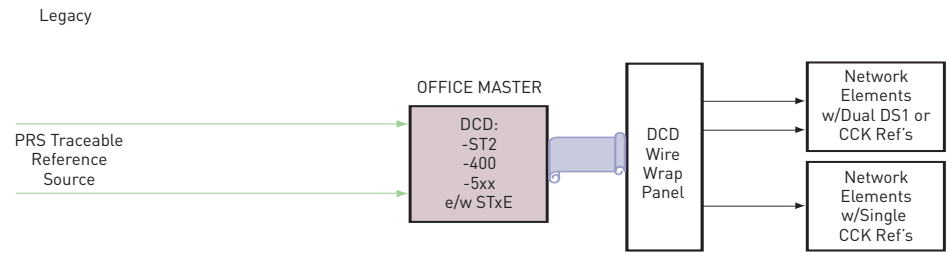

Option 1: Re-Master - Augment with a TimeHub 5500Next Generation BITS Platform

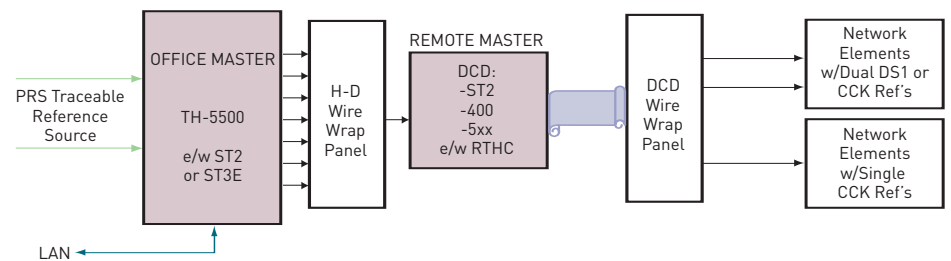

BITS Modernization First Option

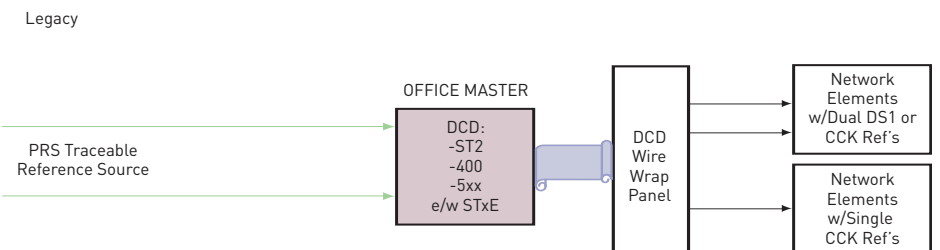

Option 2: Re-Master - Replace with a TimeHub 5500: All new Shielded Twisted Pair (STP) Cable to NE's

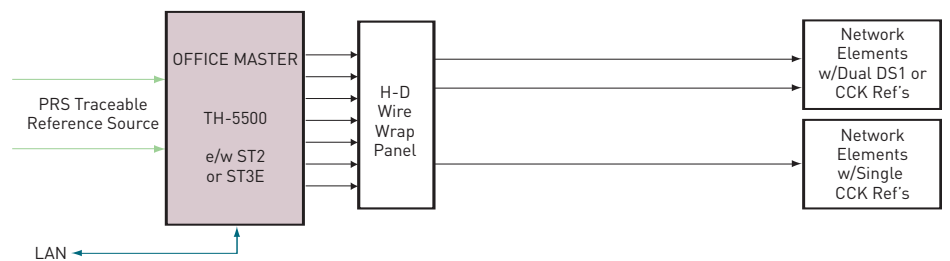

BITS Modernization Second Option

Legacy

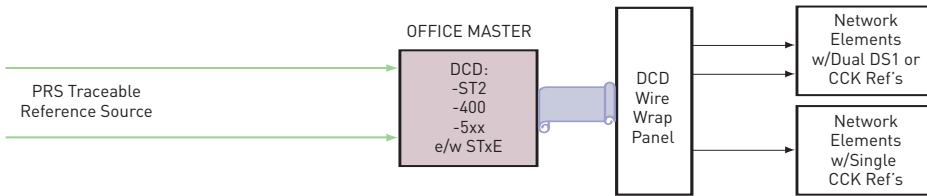

Option 3: Re-Master - Replace with a TimeHub 5500: Reuse existing wiring to NE's

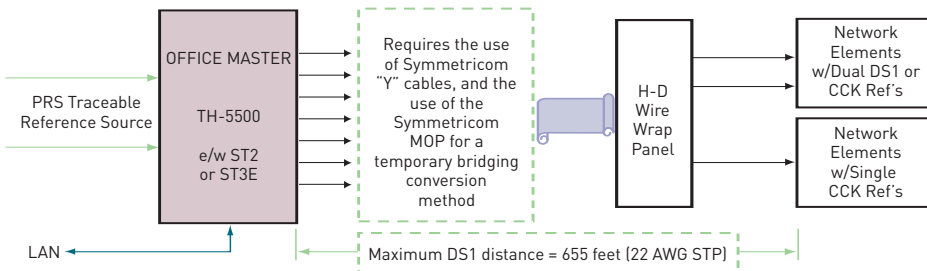

BITS Modernization Third Option

cables. This enables the continued use of existing wiring to the network elements. The TimeHub can be mounted in the same equipment bay as the legacy DCD wire wrap panels, or in a relay rack up to 200 cable feet away. The old TSG shelves are then removed, leaving the legacy wire wrap panels in place.

A modification of this arrangement is to place the TimeHub wire wrap panels in the relay rack of the old TSG and bridge the output signals, one at a time, to the new wire wrap panels. Then, the old TSG shelves are removed, as above. This option enables you to completely replace the legacy system while minimizing the immediate labor costs associated with rewiring.

Further options are available, depending on an office's configuration. These other alternatives involve removing the legacy TSG while maintaining the old wire wrap panel and wiring to the TSGs. This method is unique as it involves positioning the TimeHub 5500 TSG in a new equipment bay. Or, the new TSG can be positioned in the existing equipment bay using the Symmetricom-developed "Hot Slide" method, which will be explained later. Both methods require the use of Symmetricom "Y" cables and the MOP for a temporary bridging conversion method.

Symmetricom's certified Field Service Engineers will work with your technical staff to determine which of these alternatives best fits your objectives and budget. We will then utilize our experience to develop an in-service procedure customized to your company to install the BITS modernization configuration that you have selected. The most critical concern, bar none, is to deliver uninterrupted service to your customers from the beginning of the installation process into the future. The specific procedure depends upon which of the configurations was chosen, as well as other conditions specific to your CO.

### Overcoming Unexpected Cutover Challenges

Any installer can handle the task of moving wires from one terminal to another. It's the surprises that often arise during the installation process that separate the best from the rest. Symmetricom's certified FSEs are known for their ability to respond to and overcome unexpected challenges that may be encountered during the cutover. They understand that synchronization is one of the most critical aspects of any Central Office because any interruption in the timing signal can knock out a network element. In particular, if you make a mistake and take an SS7 link down, the whole office could potentially be isolated from the network.

Legacy

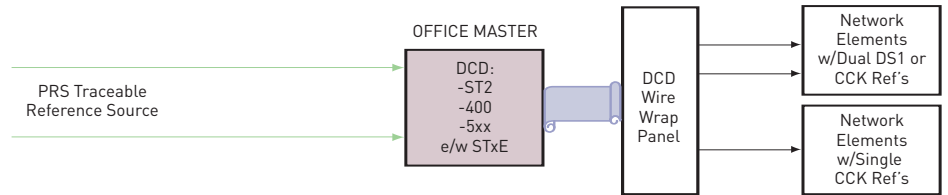

Option 4: Re-Master - Replace with a TimeHub 5500 in a new equipment bay: Reuse W-W Panel & Wiring to NE's

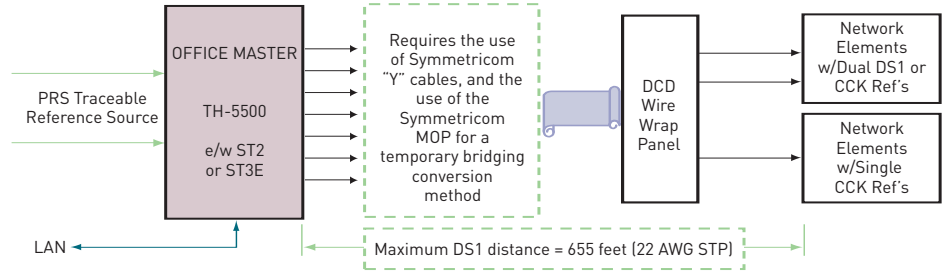

BITS Modernization Alternative Option

FSEs first overcome cutover challenges by following meticulous procedures that identify problems in plenty of time to take corrective action. For example, they pre-test each network element prior to cutover in order to verify its health before the cut is made. Examining each signal on an oscilloscope both before and after the cut makes it easy to detect problems such as the lack of a termination, or an incorrect termination, on the network element.

In one case, a network element would not accept the TimeHub 5500 DS1 signal. A look in the oscilloscope revealed a signal that was about 0.5V higher than the DCD signal. Adding a 100 ohm resistor across the tip and ring cleared this problem.

Symmetricom's certified Field Service Engineers are used to dealing with the most complex challenges. One example includes the successful cutover of a large office with both Composite Clock and T1 signals, requiring a MOP with nearly 150 steps. Symmetricom also upgraded a major metropolitan office with 1700 network elements. FSEs moved each network element to the new TimeHub 5500 Master and Remote Master shelves without a single problem. This cutover project took five nights to complete, working in the office's 12 am to 6 am maintenance window.

### General Cutover Procedures

Let's look first at the general procedure for installation in situations where the legacy TSG is removed and replaced with a new system in a new equipment bay. First, the new TimeHub is installed. An ideal installation is adjacent to the existing legacy TSG, however it can be placed as much as 200 feet away without adding complications to the cutover. All of the TimeHub outputs are tested through each driver card to ensure the presence of proper output signals. Pulling a driver card, and testing the mate, then replacing the card that was removed, pulling the mate, and testing the card that remains in place accomplishes this.

The next and highly critical step involves bridging the composite clock signals between the old and the new TSGs. An oscilloscope is used to match the frequency and phase of the two TSGs, and especially to verify that the tip and the ring do not have a 180 degree phase difference. Once aligned, the TimeHub maintains the phase of the legacy TSG for many days, making it possible to take as much time as is needed for the cutover. In the case of the large offices, as many days can be taken as are needed to accomplish the cut and clear issues as they develop.

Legacy

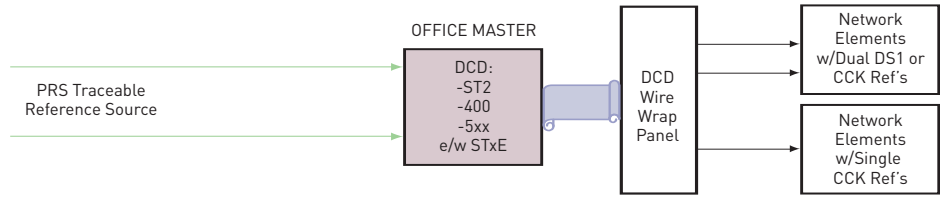

Option 5: Re-Master - Replace with a TimeHub 5500 in the existing equipment bay via the Symmetricom "Hot Slide": Reuse W-W Panel & Wiring to NE's

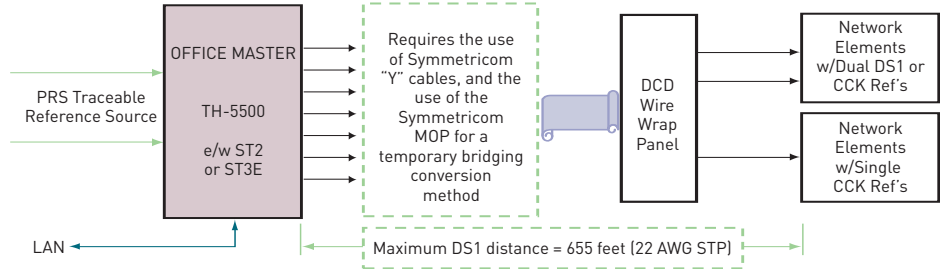

BITS Modernization "Hot Slide" Option

A temporary "cutover" cable from the new TSG is then attached to the legacy wire wrap panel Composite Clock output ports (ten at a time). The cutover cable bridges the new Composite Clock signals onto the existing signal while the old output cable is replaced by the new output cable. DS1 signals are then cut over, also ten ports at a time, using a similar procedure.

Network elements are monitored during the cutover for alarm activity. At the end of this process, the TimeHub generates the required synchronization signals through the legacy wire wrap panel. From that point, the signals pass through the in-place distribution cables to the network elements. The legacy TSG card cages are removed, leaving the legacy system's wire wrap panels and distribution cables in place.

### Hot Slides

A hot slide is required in cases where there is no relay rack available to install the new Master near the old Master. In this case, the new Master is installed external to the relay rack, usually behind the old Master. The new Master and High-Density Wire Wrap panel can be secured to the top of a step ladder or other device, powered up and cut over one lead at a time, using a process similar to the one described above. After all the network elements are transferred to the new Master, the old Master is powered down and removed

from the rack along with the old wire wrap panel. The new Master is then moved while it continues to operate into the space vacated by the old Master and secured in place. Thus, the name "hot slide".

### Conclusion

Symmetricom's certified Field Service Engineers have the technical and practical experience to develop an optimal BITS configuration and cut over any office from a legacy system to a Next Generation TSG. They cover all the details from floor to roof, with thoroughly trained and tested personnel. Field Service Engineers have developed cutover procedures to detect potential issues in advance, with the ultimate goal of zero impact on your network. But on those rare occasions when something completely unexpected happens, you'll discover why Symmetricom is often called in to finish unsuccessful cutovers that were started by other companies. When your company's reputation and revenues are on the line, can you afford less than the best?



**SYMMETRICOM, INC.**  
**CORPORATE**  
2300 Orchard Parkway  
San Jose, California  
95131-1017  
tel: 408.433.0910  
fax: 408.428.7896  
info@symmetricom.com  
www.symmetricom.com